

CDP Specifications

The CDP series was designed for use as customizable multi-line displays for transit applications. Several standard panel sizes are available, but panels can be stacked and extended as needed to meet any size requirement. The CDP's dense matrix is ideal for displaying different categories of information simultaneously, ie. route information, current time and advertisements.

Brightness	9,000 - 12,000 Nits
Color Options	Red, Amber, Blue, Green or White
Viewing Angle	120°
Viewing Distance	3 ft - 250 ft (Depending on character height)
Controller	Embedded
Communication Options	Ethernet, Cell modem, Serial
Display Functions	Scroll string left Scroll image left Show string centered Show string right justified Show image left justified Show image right justified Show string left justified Show image centered Content Flashing
Humidity Range	0 - 90% non-condensing
Operating Temperature Range	-20 - 80° C
Enclosure	IP65 rated cabinet. Custom sizes can be built to accomodate larger matrix sizes and additional internal sign components.

MODEL OPTIONS

	CDP-10	CDP-20	CDP-32	CDP-40
Matrix (Rows x Columns)	10 x 144	20 x 144	32 x 156	40 x 200
Pixel pitch	.26" (6.6 mm)	.26" (6.6 mm)	.29" (7.3 mm)	.225" (5.7 mm)
Max. Number of Lines	One	Two	Four	Five
Std. Enclosure Dimensions	11" H x 39" L	11" H x 39" L	10.75" H x 49.50" L	10.75" H x 49.50" L
Power (watts)	132 peak; 33 avg.	132 peak; 33 avg.	1000 peak; 300 avg.	1000 peak; 300 avg.
Weight (without components)	20 lbs.	20 lbs.	15 lbs. per side	15 lbs. per side

FEATURES

- Internal real-time clock for date and time display
- Fallback program
- Light sensor to adjust brightness
- Shock sensor to disable output of sign
- Multiple scroll rates
- LED matrix can be configured into user-defined viewable areas. Each area runs its own program with its own scroll rate and font. Area programs can be synchronized, so an external source can set the pace of the programs.
- Multiple font heights

CODE FOR PRODUCT NUMBERS EX. CDP-32X156R

CDP 32 156 R
 (series name) (matrix height) (matrix length) (color)

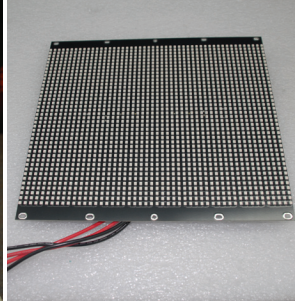

TOP, FRONT AND BOTTOM VIEW

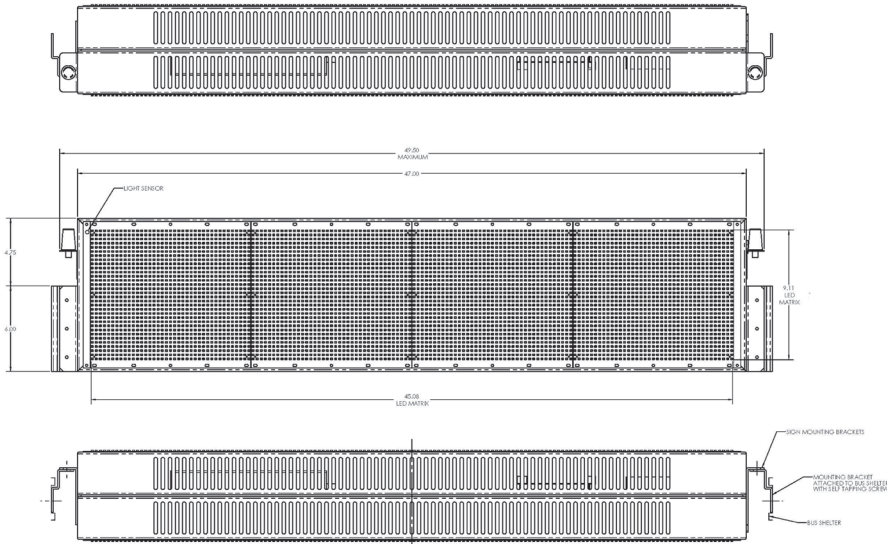

SIDE VIEW

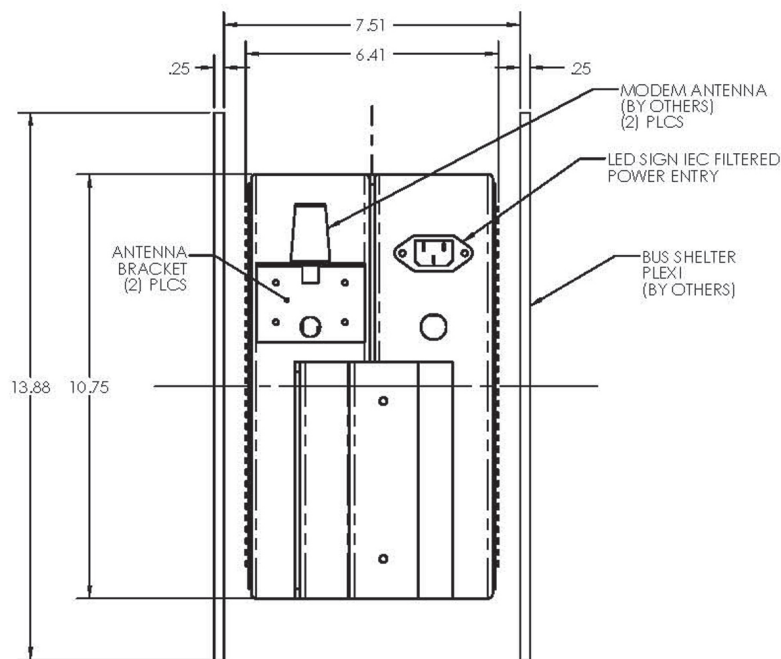

ABOUT US

Sunrise Systems

An industry leader since 1976, Sunrise Systems has built LED products for everyone from small businesses to major corporations. Our award-winning systems are installed in transit systems, financial institutions, malls, museums, theaters, casinos, convention halls, and ballparks worldwide. If you can imagine it, Sunrise Systems can create it – from tiny hand-held devices to soaring architectural installations with dynamic moving messages. We have the experience, the expertise and the passion to capture a vision and execute with success. Contact us today to learn how we can help get your idea up in lights.

CONTACT

SUNRISE SYSTEMS INC.

720 Washington Street
Pembroke, MA 02359

☎ 781.826.9706

☎ 781.826.0061

sunrisesystems.com

sales@sunrisesystems.com